

Turb 550 / Turb 550 IR

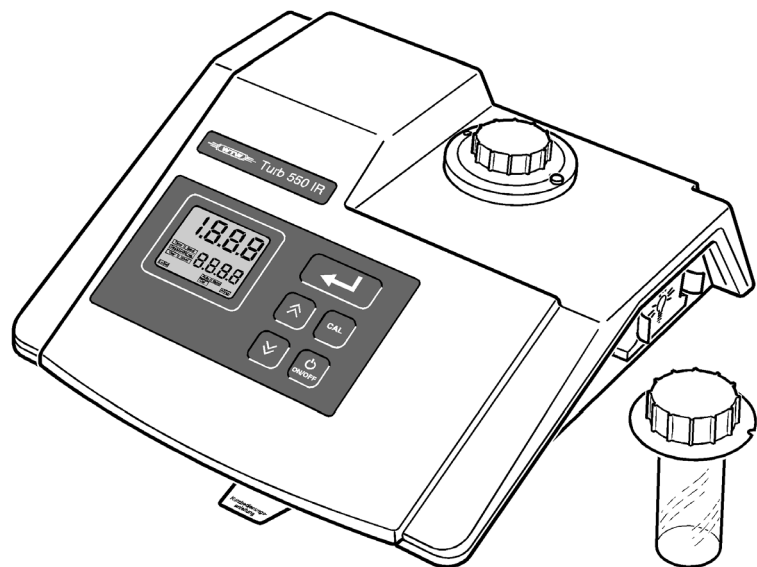

Turbidity Measuring Instrument

Accuracy when going to press

The use of advanced technology and the high quality standard of our instruments are the result of continuous development. This may result in differences between this operating manual and your instrument. We cannot guarantee that there are absolutely no errors in this manual. We are sure you will understand that we cannot accept any legal claims resulting from the data, figures or descriptions.

Warranty declaration

The designated instrument is covered by a warranty of 2 years from the date of purchase.

The instrument warranty extends to manufacturing faults that are determined within the period of warranty. The warranty excludes components that are replaced during maintenance such as lamps, etc.

The warranty claim extends to restoring the instrument to readiness for use but not, however, to any further claim for damages. Improper handling of the instrument invalidates any warranty claim.

To ascertain the warranty liability, return the instrument and proof of purchase together with the date of purchase freight paid or prepaid.

Copyright

© Weilheim 2009, WTW GmbH

Reprinting - even in the form of excerpts - is only allowed with the explicit written authorization of WTW GmbH, Weilheim.

Printed in Germany.

1	Overview	5
1.1	Keypad	6
1.2	Display	7
1.3	Sockets	7
2	Safety	9
2.1	Authorized use	10
2.2	General safety instructions	10
3	Commissioning	13
3.1	Initial commissioning	13
3.2	Connecting the plug-in power supply	14
3.3	Switching on the measuring instrument	15
4	Operation	17
4.1	Instructions for operating	17
4.1.1	Marking and aligning cells	17
4.1.2	Venting the sample	19
4.2	Measuring turbidity	20
4.2.1	Standard measurement	20
4.2.2	Measuring turbidity using the flow-through vessel (accessory)	23
4.3	Calibration	27
4.4	Configuring the instrument	31
4.4.1	Changing settings	31
4.4.2	Reset	34
4.5	Documentation	35
4.5.1	Connecting the printer	35
4.5.2	Printing	35
5	Maintenance, cleaning, disposal	37
5.1	Maintenance	37
5.1.1	Changing the lamp module	37
5.1.2	Changing the batteries	38
5.2	Cleaning	40
5.2.1	Cleaning the measuring instrument	40

5.2.2	Cleaning the cells	40
5.3	Disposal	41
6	What to do if	43
7	Technical data	45
8	Accessories (options)	47
9	Abbreviations and index	49

1 Overview

The Turb 550 / Turb 550 IR lets you perform turbidity measurements rapidly and reliably.

The measuring method used in the Turb 550 IR corresponds to the ISO 7027 / DIN 27027. The measuring method used in the Turb 550 follows the US EPA construction recommendations.

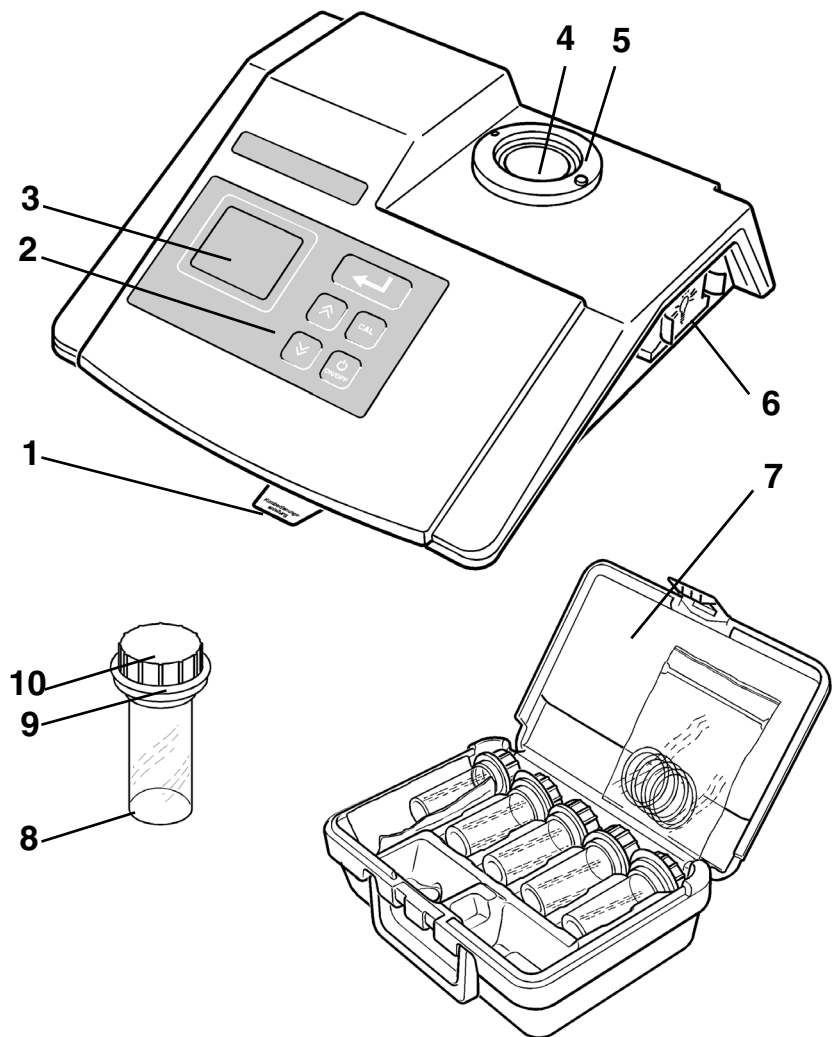



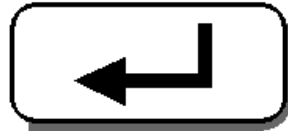

- 1 Short instructions
- 2 Keypad
- 3 Display
- 4 Cell shaft
- 5 Marker pin

- 6 Lamp module
- 7 Accessories case
- 8 Cell
- 9 Marker ring
- 10 Light protection cap

1.1 Keypad



-  key
Store/output the measured value
-  key
Increase values; Select settings
-  key
Reduce values; Select settings
-  key
Call up/terminate calibration procedure
-  key
Switch measuring instrument on/off

1.2 Display

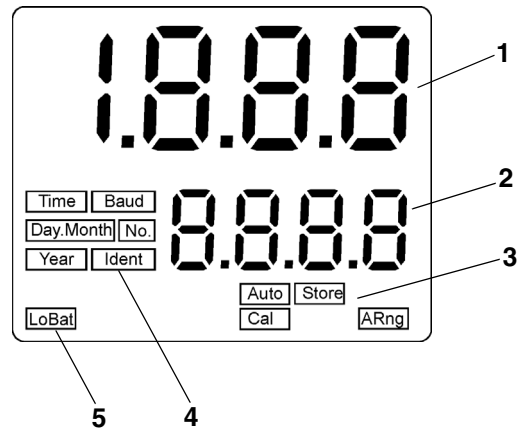

- 1 Upper display line:
Meas. value display in NTU / operating guide
- 2 Lower display line:
Stored meas. value / operating guide / error messages
- 3 Status displays
- 4 Operating guide on setting up
- 5 LoBat: Request to change the battery

1.3 Sockets

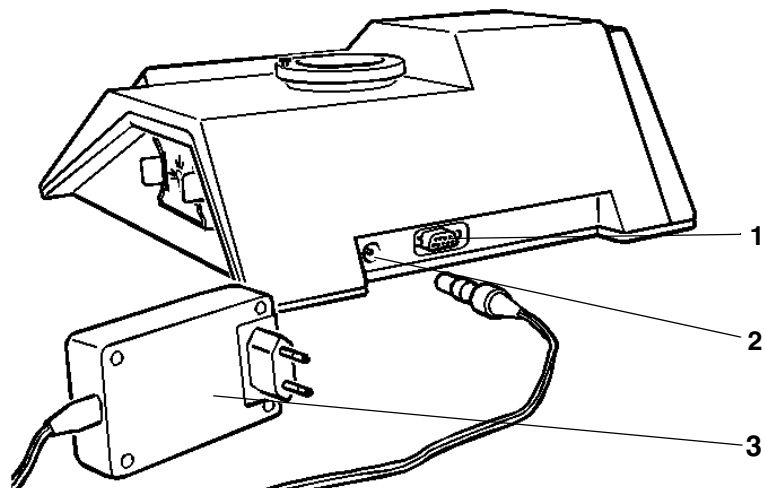

- 1 RS232 interface
- 2 Socket for plug-in power supply
- 3 Plug-in power supply

2 Safety

This operating manual contains basic instructions that you must follow during the commissioning, operation and maintenance of the instrument. Consequently, all responsible personnel must read this operating manual before working with the instrument.

The operating manual must always be available within the vicinity of the instrument.

Target group

This measuring instrument was developed for use in the laboratory. Thus, we assume that, as a result of their professional training and experience, the operators will know the necessary safety precautions to take when handling chemicals.

Symbols used



CAUTION

indicates notes that you must read to protect your instrument from damage.



Note

indicates notes that draw your attention to special features.



Note

indicates references to other documents, e.g. application reports, operating manuals of measuring chains, etc.

2.1 Authorized use

This instrument is authorized exclusively for use in measuring turbidity in the laboratory.

The technical specifications as given in the chapter, TECHNICAL DATA, must be observed. Only the operation and running of the measuring instrument according to the instructions given in this operating manual is authorized. Any other use is considered **unauthorized**.

2.2 General safety instructions

This instrument left the factory in a safe and secure technical condition.

Function and operational safety

The smooth functioning and operational safety of the instrument can only be guaranteed if the generally applicable safety measures and the specific safety instructions in this operating manual are followed.

The smooth functioning and operational safety of the instrument can only be guaranteed under the climatic conditions specified in the chapter, TECHNICAL DATA.

If the instrument was transported from a cold environment to a warm environment, the formation of condensate can lead to the faulty functioning of the instrument. In this event, wait until the temperature of the instrument reaches room temperature before putting the instrument back into operation.

Safe operation

If safe operation is no longer possible, the instrument must be taken out of service and secured against inadvertent operation.

Safe operation is no longer possible if:

- the instrument has been damaged in transport,
- the instrument has been stored under adverse conditions for a lengthy period of time,
- the instrument is visibly damaged,
- the instrument no longer operates as prescribed in this manual.

In you are in any doubt, please contact the supplier of the instrument.

Obligations of the operator

The operator of this measuring instrument must ensure that the following laws and guidelines are observed when using dangerous substances:

- EEC directives for protective labor legislation
- National protective labor legislation
- Safety regulations
- Safety datasheets of the chemical manufacturer

3 Commissioning

Scope of delivery

- Turb 550 or Turb 550 IR laboratory measuring instrument with short instructions card
- Operating manual
- Universal plug-in power supply with country-specific adapter
- ZBK accessory case with 3 calibration standards, 2 empty cells, 5 marker rings, cell cleaning cloths

Inserting the card with the short instructions

3.1 Initial commissioning

The first time the instrument is commissioned, you must insert the card that was delivered containing the short instructions into the underside of the measuring instrument:

1	Turn the instrument around and carefully put it down
2	Insert the card with the short instructions so that the English side is not visible
3	Turn the instrument around again. The short instructions card can now be pulled forward from under the instrument.

3.2 Connecting the plug-in power supply

- | | |
|---|--|
| 1 | Plug the original WTW plug-in power supply (1) into the socket (3) of the measuring instrument |
| 2 | Plug in the appropriate adapter (2) to the plug-in power supply |
| 3 | Connect the plug-in power supply to an easily accessible socket. |

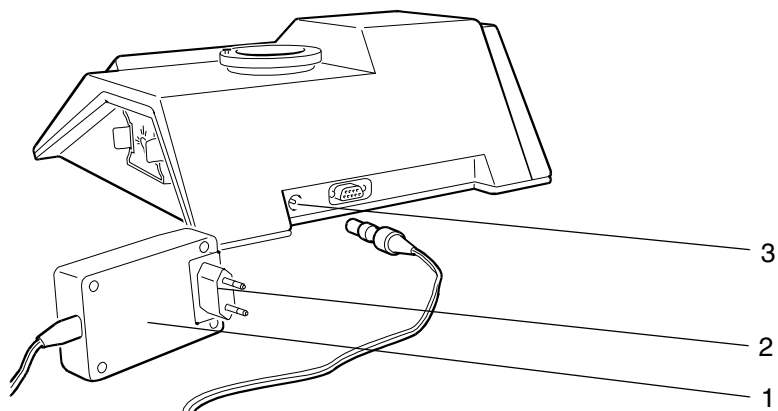

3.3 Switching on the measuring instrument

- | | |
|---|---|
| 1 | Place the measuring instrument on a flat surface and protect it against intensive light and heat |
| 2 | Press the  key.
All the display elements appear briefly on the display. The measuring instrument then switches automatically to the measuring mode: A measured value and the <i>Auto</i> display appear |
| 3 | Set the date and time, if necessary (see 4.4.1 CHANGING SETTINGS) |
| 4 | The measuring instrument has a warm-up period of at least 30 minutes. After this time, the measuring instrument measures with the specified accuracy. |

Sample display

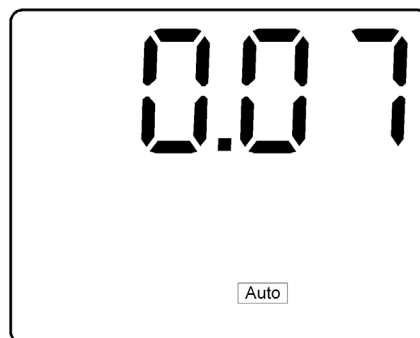

Note

Even if it is not measuring, always leave a cell plugged into the instrument so that the cell shaft is protected against dust.

4 Operation

4.1 Instructions for operating

4.1.1 Marking and aligning cells

Even completely clean quality cells exhibit tiny differences in their light transmittance. Therefore, we recommend marking each cell (both measuring cells as well as cells with the calibration standard). Consequently, each cell can always be inserted in the correct position and you can achieve precise measuring results.



Note

Never apply oily liquids (or so-called "special silicone oils") in order to "smooth" possible scratches. They would unnecessarily soil the meter and your working environment. The measurement accuracy is ensured by aligning the cuvettes. Scratched cuvettes have to be replaced.

Cleaning the cell

The cell must be absolutely clean (see 5.2.2 CLEANING THE CELLS).

Marking the cell

This is how to mark a cell (empty or full):

1	The cell must be closed with the black light protection cap. Make sure that the outside of the cell is clean, dry and free of fingerprints
2	Insert the cell in the cell shaft of the turbidity measuring instrument
3	Slowly rotate the cell through one complete rotation (by 360°)
4	Watch the display of the turbidity measuring instrument while you rotate the cell. Leave the cell in the position that gives the lowest display.
5	Attach a marker ring to the black light protection cap of the cell. The arrow on the marker ring must point to the marker pin on the casing of the cell shaft.

- 6 | Leave the marker ring on the light protection cap of the cell. This cell is now permanently marked.



Note

Always use the cell and the light protection cap together; only in this way is the cell marked.

Aligning a marked cell

A marked cell is aligned as follows:

1	Insert the cell in the cell shaft on the turbidity measuring instrument
2	Align the marked cell so that the arrow on the marker ring points to the marker pin on the casing of the cell shaft.

Aligning an unmarked cell

An unmarked cell is aligned as follows:

1	Insert the cell in the cell shaft on the turbidity measuring instrument
2	Slowly rotate the cell through one complete rotation (by 360°)
3	Watch the display of the turbidity measuring instrument while rotating the cell. Leave the cell in the position that gives the lowest display.

Balancing cells

Even insignificant variations in the glass can affect the measured value. For this reason, always use the same cell or balance a pair of cells for low turbidity values:

1	Fill the first cell with the sample, align it and mark it (see 4.1.1 MARKING AND ALIGNING CELLS)
2	Press the  key to store the measured value
3	Fill the second cell with the same sample and insert it in the cell shaft

4	Rotate the cell until the same measured value is displayed as for the first cell
5	Mark the cell with a marker ring.

4.1.2 Venting the sample

Air bubbles in the sample affect the measuring result to a massive extent because they have a large scattering effect on the incident light. Larger air bubbles cause sudden changes in the measured values whereas smaller air bubbles are recorded by the instrument as turbidity. Therefore, avoid or remove air bubbles:

Avoiding or removing air bubbles

- During sampling, ensure all movement is kept to a minimum
- If necessary, vent the sample (ultrasonic baths, heating or adding a surface-active substance to reduce the surface tension)
- Use a flow-through vessel.

4.2 Measuring turbidity

4.2.1 Standard measurement

Preparatory activities

Perform the following preparatory activities when you want to begin measuring:

1	Switch on the instrument
2	Wait for at least 30 minutes to allow for the warm-up time.



Note

Incorrect calibration of the turbidity measuring instrument results in incorrect measured values. Carry out the calibration regularly at the specified fixed intervals.



Note

The outside of the cell must always be clean, dry and free of fingerprints. Clean the cell before starting to measure (see 5.2.2 CLEANING THE CELLS). Only hold the cells at the top or by the black light protection cap.



Measuring

How to measure the turbidity of a sample:

1	Rinse out a clean cell with the sample to be measured: Pour approximately 20 ml sample into the cell. Close the cell and rotate it several times before throwing the sample away
2	Repeat the rinsing procedure twice more
3	Fill the cell with the sample to be measured (approx. 30 ml). Close the cell with the black light protection cap
4	Make sure that the outside of the cell is clean, dry and free of fingerprints
5	Insert the cell in the cell shaft of the turbidity measuring instrument
6	Align the cell (see 4.1.1 MARKING AND ALIGNING CELLS)

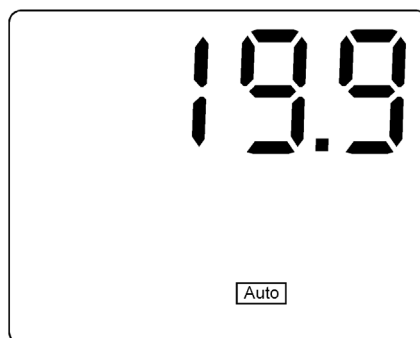
- 7 The turbidity value appears in nephelometric turbidity units (NTU) on the display. The instrument automatically selects the measuring range and resolution



- 8 If you want to measure and compare more than one sample, press the  key. The last measured value is stored and appears in the lower display line. The upper display line continues to show the current measured value. If the print function is switched on, the value can also be output on the RS232 interface by pressing the  key

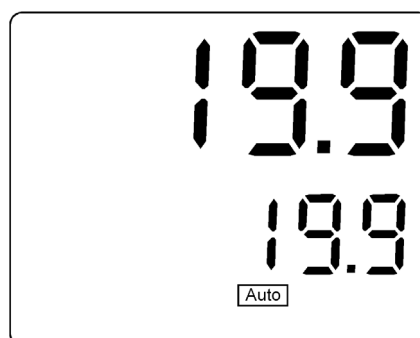

- 9 Repeat steps 1 to 8 for all the samples
- 10 After measuring, always leave a cell plugged into the instrument so that the optical shaft is protected against dust.

If the print function is switched on and a printer or PC is connected and switched on, the time, date and measured value will be output by pressing :

Sample printout

13:17	15 JAN 1999	19.09 NTU
13:18	15 JAN 1999	756 NTU

4.2.2 Measuring turbidity using the flow-through vessel (accessory)

The pour-through vessel (WTW order number 600600) fits any Turb 550 instrument and enables you to measure several samples one after another quickly and easily. Any interference effects caused by air bubbles are reduced. Besides, you do not have to use balanced cells for comparative measurements as always the same cell is used.

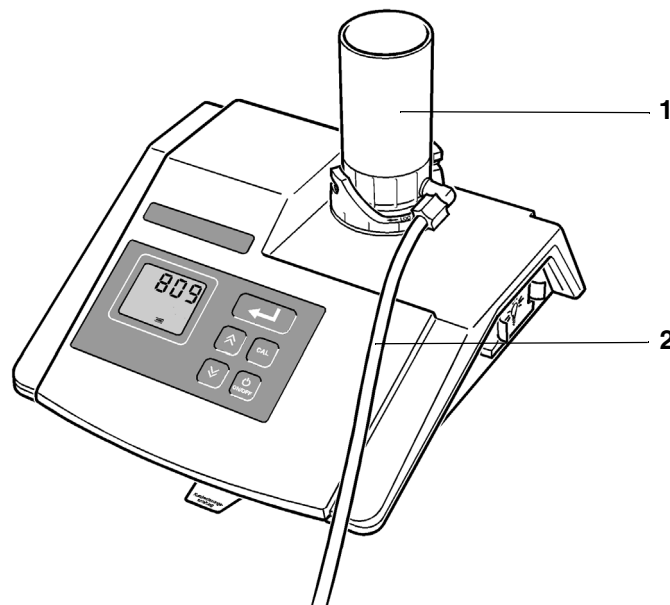

- 1 Flow-through vessel
- 2 Outlet hose

Preparatory activities

Carry out the following preparatory activities before you install the flow-through vessel:

- | | |
|---|--------------------------------------|
| 1 | Switch on the instrument |
| 2 | Wait for the 30 minute warm-up time. |

Installing a flow-through vessel

To install the flow-through vessel, proceed as follows:

1	Pull the white marker pin out of the casing (2) of the cell shaft
2	Unscrew and remove the casing (2) using the tightening key (8) provided
3	Place the fixing ring (1) on the cell shaft
4	Reattach the casing (2) and tighten it up using the tightening key (8)
5	Insert the white marker pin again in one of the holes on the casing
6	Insert the sealing ring provided (3) into the casing of the cell shaft
7	Screw the screw-in cell (7) into the base of the flow-through vessel (5)
8	Make sure that the outside of the cell is clean, dry and free of fingerprints
9	Insert the flow-through vessel (5) with the cell at the bottom into the cell shaft of the measuring instrument
10	Align the flow-through vessel with the cell (see ALIGNING AN UNMARKED CELL)
11	Leave the flow-through vessel in this position and hold it by the lower, knurled section
12	Using the other hand, turn the fixing ring (1) clockwise so that it clicks into place and secures the flow-through vessel
13	Plug the outlet hose onto the outlet (4) and position it so that its end is lower than the flow-through vessel and the sample can run out into a suitable vessel or drain
14	Replace the lid (6).

**Note**

The flow-through vessel can remain installed until the next calibration.

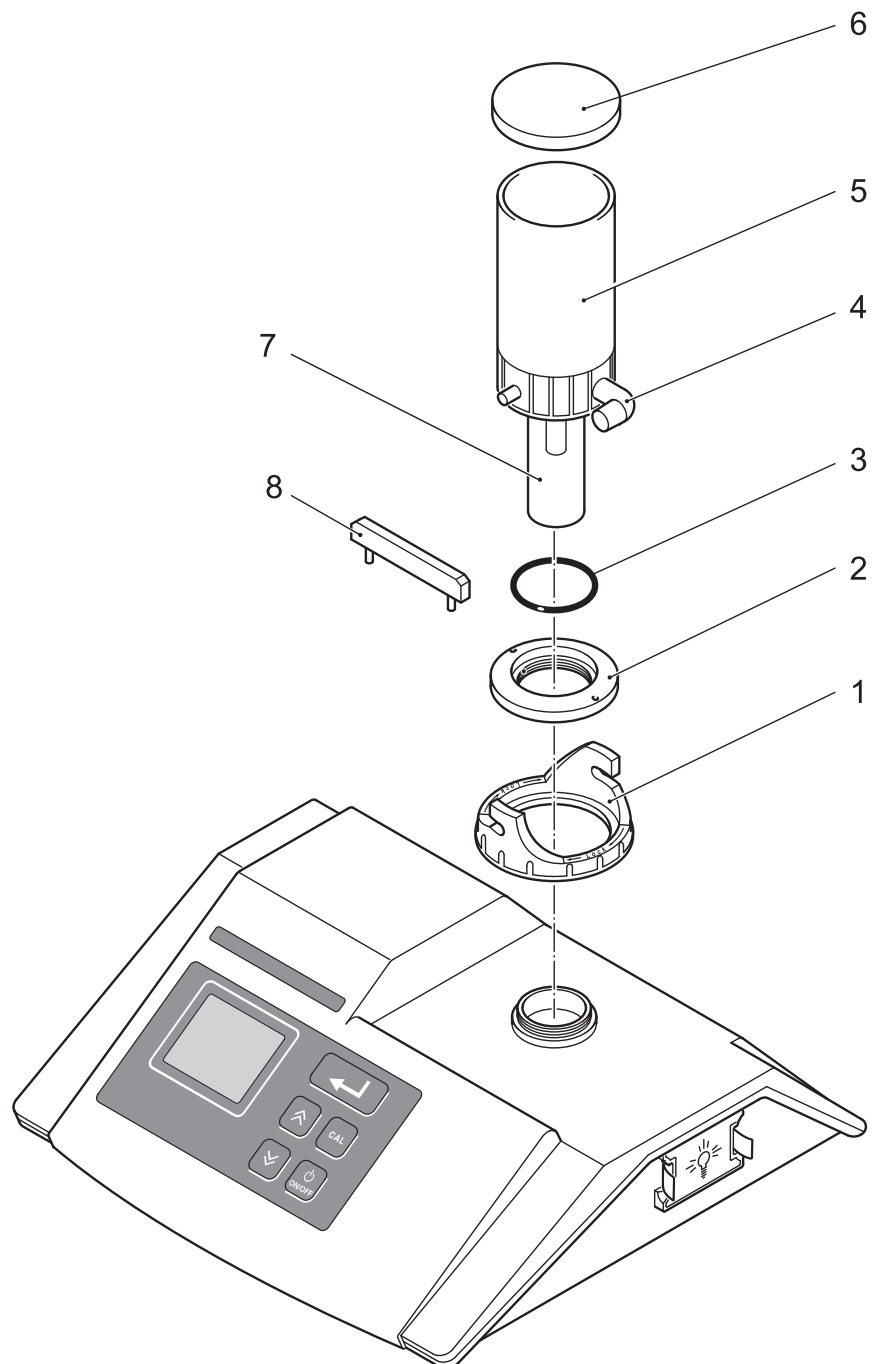



**Note**

If you use the flow-through vessel, you do not need to rinse the cell 3x with the sample. The sample rinses the cell as it flows through. Even the forming of air bubbles is considerably reduced.

Measuring

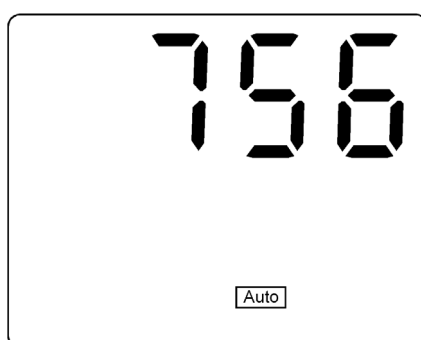
1	Remove the cover from the flow-through vessel
2	Slowly pour approximately 500 ml sample into the container of the flow-through vessel. The sample runs through the vessel into the cell and any excess sample runs out again through the outlet hose. In this way, any "old" sample liquid that remains will be displaced
3	When no more liquid runs out of the outlet hose, wait for a stable measured value and read it



4	If you want to measure and compare several samples, press the  key. The last measured value is stored and appears in the lower display line
5	Repeat steps 1 to 4 for all the samples.

**Note**

If you pour in samples that are too cold, the outside of the cell may mist up causing the measured value to be much too high. We recommend waiting until the sample has reached room temperature before filling.

4.3 Calibration

Why calibrate?

As with every measuring instrument, the measuring accuracy of the turbidity measuring instrument must be checked and adjusted at regular intervals.

For this purpose, 3 calibration standards (1000 NTU, 10 NTU, 0.02 NTU) that were specially developed for this instrument are supplied with the instrument.



Note

Always use the calibration standards that were delivered with the instrument to calibrate it. Check that they have not passed the expiry date!

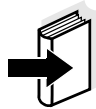

Note

Basically, for measurements according to DIN/ISO and also for standard methods, calibrations with formazin are required. See Application report 998 255 HERSTELLUNG VON FORMAZIN-PRIMÄRSTANDARD (PREPARATION OF FORMAZIN PRIMARY STANDARD) **for more information.**

Preparatory activities

Perform the following preparatory activities if you want to calibrate:

1	Switch on the measuring instrument
2	Wait for the 30 minute warm-up time
3	Have the calibration standard ready
4	Make sure that the outside of the cell is clean, dry and free of fingerprints.



CAUTION

Never open the cells containing the calibration standard!

Calibration

How to calibrate your measuring instrument:

- 1 Press the  key. The Ident display and the Cal display appear. The number 1000 appears in the lower display line

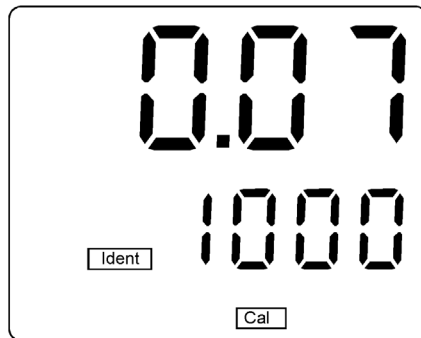

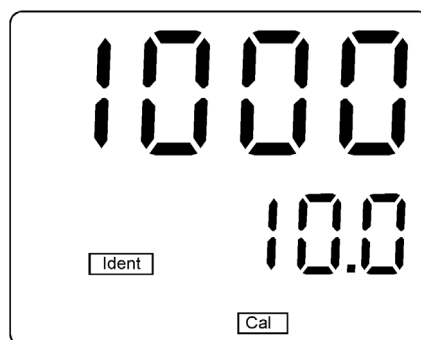

- 2 Insert the 1000 NTU calibration standard in the cell shaft
- 3 Align the cell and wait for a stable measured value
- 4 Press the  key. The Store display flashes for approximately 3 seconds. The number 1000 (NTU) appears in the upper display line. The number 10.0 (NTU) appears in the lower display line

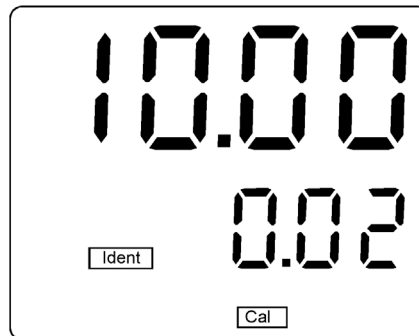

- 5 Insert the 10.0 NTU calibration standard in the cell shaft
- 6 Align the cell and wait for a stable measured value

- 7 Press the  key.
The Store display flashes for approximately 3 seconds. The number 10.0 (NTU) appears in the upper display line. The number 0.02 (NTU) appears in the lower display line



- 8 Insert the 0.02 NTU calibration standard in the cell shaft
- 9 Align the cell and wait for a stable measured value
- 10 Press the  key.
The calibration is complete and the instrument returns automatically to the normal measuring mode.



Note

It is only possible to switch the instrument off after the calibration has been finished.



Notes

- The measuring instrument has an automatic 1 to 3 point calibration. This means that you can also perform calibration using one or two standards instead of all three.
- 1 point and 2 point calibrations are makeshift solutions. They do not reset the calibration timer. After performing a calibration using one or two standards, press the  key and the measuring instrument returns to its normal measuring mode.
- After a 1 point calibration, measuring is only possible in the immediate vicinity of the calibration point.
- For a 2 point calibration, you must use 2 calibration stan-

dards next to each other. Measuring is then possible with a reduced accuracy between the calibration points.

- To achieve the precision specified in the technical data, you must perform the calibration using all 3 calibration standards in the specified sequence.

If the print function is switched on and a printer or PC is connected and switched on, the following printout or display is output:

Sample printout

DATE:	15 JAN 1999	13:20	<i>Current date and time</i>
LAST CAL:	17 DEC 1998	17:03	<i>Date and time of the last calibration</i>
CALIBRATION INTERVAL:	30 DAYS		<i>Calibration interval: 30 days</i>
CALIBRATION POINTS:			<i>Calibration points</i>
STANDARD	DATE	TIME	
0.02 NTU	15 JAN 1999	13:20	<i>Calibration standard used with date and time</i>
10.0 NTU	15 JAN 1999	13:20	
1000 NTU	15 JAN 1999	13:19	
30 DAYS UNTIL NEXT CALIBRATION			<i>30 days until the next calibration</i>

4.4 Configuring the instrument

4.4.1 Changing settings

You can perform the following settings:

- Date (YYYY/MM/DD)
- Time (min/sec)
- Calibration interval (1 - 99 days)
After the set calibration interval expires, the Cal message appears on the display until the measuring instrument has been recalibrated).
- Print function (on or off)
If the print function has been set up, measured values that have been confirmed by the  key are output on the RS232 interface (to a connected printer or PC).
- Baud rate (1200, 2400, 4800, 9600 - only if the print function is active)

The settings remain stored in the instrument.





Note



Settings are made in this measuring instrument following a compelled guidance. If you have called up the setting function once, you can only leave this function if you have run through all the settings one after the other and confirmed this by pressing the  key. Following the last possible setting, the instrument returns to its normal measuring mode. You can switch off the instrument only after you have left the setting function.

Making settings



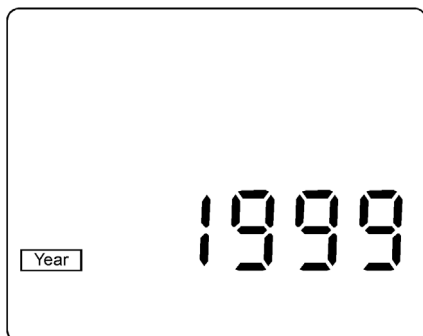



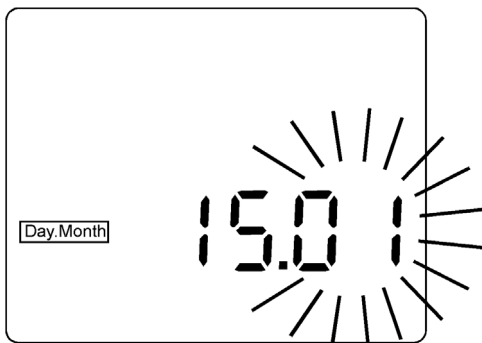

If you want to make any settings, proceed as follows:

- 1 Press the  and  keys at the same time. The Year message and the set up year, e.g. 1999, appears





- | | |
|---|---|
| 2 | To change the year, press  or  |
| 3 | Confirm by pressing  . The instrument automatically shows the next possible setting, the date. The Day.Month message appears and the number of the month flashes |



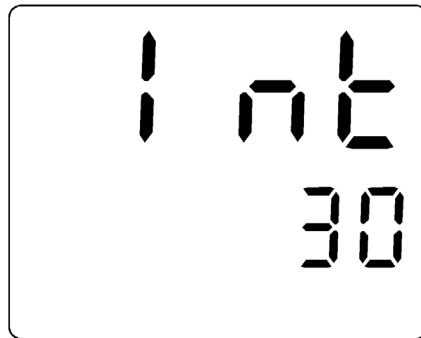



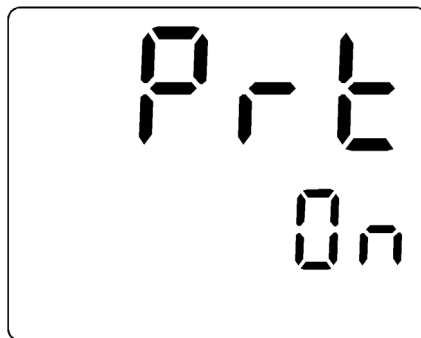

- | | |
|---|---|
| 4 | To change the month, press  or  and confirm by pressing  . The number of the day flashes |
| 5 | To change the day, press  or  and confirm by pressing  . The Time display appears |
| 6 | Set the time (minutes and seconds) with  or  and confirm by pressing  . The Int (calibration interval) message appears |



- | | |
|---|--|
| 7 | To change the calibration intervals, press  or  until the required number of days is displayed |
| 8 | Confirm by pressing  . The Prt (printing) message appears |





- | | |
|----|--|
| 9 | To switch the print function to on (On) or off (OFF), press  or  until the required setting is displayed |
| 10 | Confirm by pressing  . If the print function was switched off, the instrument returns to its normal measuring mode. If the print function was switched on, the Baud message appears |
| 11 | Set the required Baud rate by pressing  or  |
| 12 | Confirm by pressing  . The settings are complete and the instrument returns to its normal measuring mode. |

Basic settings**4.4.2 Reset**

The following functions are reset to the delivery status (initialized) if a Reset is performed:

Setting point	Delivery status
Calibration interval	30 days
Printing	Off
Baud	4800

To reset the settings, proceed as follows:

- 1 | Press the  key and hold it down
- 2 | Press the  key.

The settings are reset to the status they had on delivery. The instrument continues to operate in the normal measuring mode. The date and time must be set again.

4.5 Documentation

If the instrument is connected to a printer or PC, the measured values can be documented via the printer or PC. Information on suitable cables and the printer is given in 8 ACCESSORIES (OPTIONS).

4.5.1 Connecting the printer

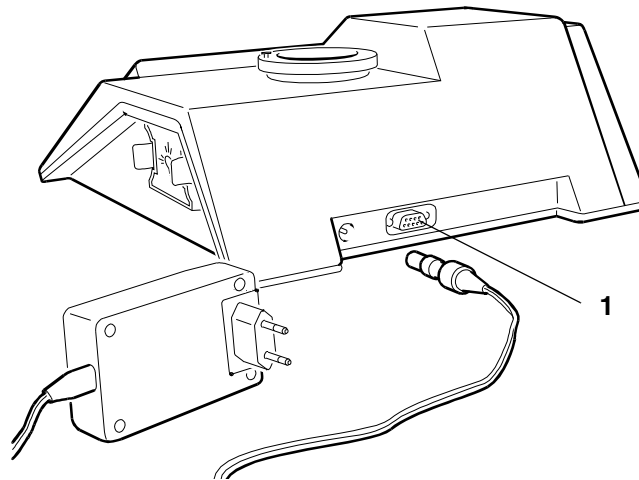

- | | |
|---|---|
| 1 | Plug the printer cable into the RS232 interface (1) of the instrument |
| 2 | Connect the printer cable to the printer |

4.5.2 Printing



Note

Printing can only function if the measuring instrument is switched on and the print function is active (on). In addition, the correct Baud rate must be set up (4800 Baud).

- | | |
|---|---|
| 1 | Switch on the printer |
| 2 | Press the  key. The measured value is printed together with the time and date. |

Sample printout

13:17	15 JAN 1999	19.09 NTU
13:18	15 JAN 1999	756 NTU



Note

After calibration, if the print function is switched on and a printer is connected, the calibration protocol is printed out automatically.

Sample printout

DATE:	15 JAN 1999	13:20	<i>Current date and time</i>
LAST CAL:	17 DEC 1998	17:03	<i>Date and time of the last calibration</i>
CALIBRATION INTERVAL:	30 DAYS		<i>Calibration interval: 30 days</i>
CALIBRATION POINTS:	<i>Calibration points</i>		
STANDARD	DATE	TIME	
0.02 NTU	15 JAN 1999	13:20	<i>Calibration standard used with date and time</i>
10.0 NTU	15 JAN 1999	13:20	
1000 NTU	15 JAN 1999	13:19	
30 DAYS UNTIL NEXT CALIBRATION			<i>30 days until the next calibration</i>

5 Maintenance, cleaning, disposal

5.1 Maintenance

The measuring instrument is largely maintenance-free. The maintenance required consists merely of changing the lamp module and replacing the batteries.

5.1.1 Changing the lamp module

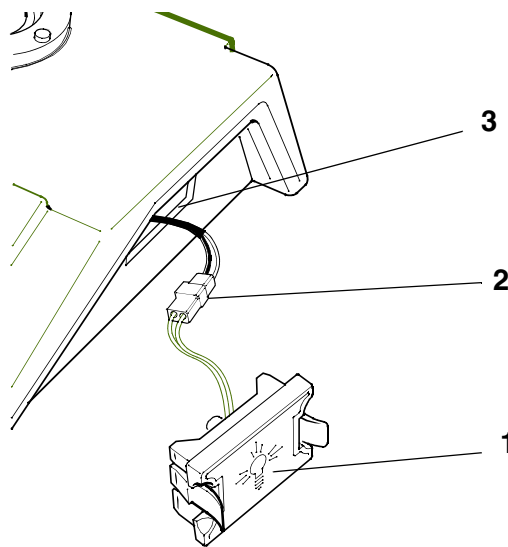

1	Switch off the measuring instrument and disconnect it from the mains
2	Take out the lamp module (1): Press the two grips gently together and carefully pull out the lamp module until the plug-in connection (2) is visible
3	Pull the plug-in connection (2) apart and, thus, remove the lamp module. Do not pull on the wires while doing this
4	Plug in the new lamp module to the plug-in connection of the instrument. Do not touch the lamp with the fingers

5	Stow the wires in the opening (3) of the measuring instrument again. Make sure that the wires are not placed in front of the lamp and that they are not in the way of the lamp module
6	Insert the new lamp module (lamp symbol must be vertical) so that it locks into place and a click can be heard
7	Connect the instrument to the mains supply again and switch it on
8	Calibrate the instrument (see 4.3 CALIBRATION). The instrument is now ready for operation again.

5.1.2 Changing the batteries

The batteries must be changed when the *LoBat* message appears (approx. every 3 years). We recommend to have the batteries exchanged by service personnel. If you want to exchange the batteries by your own, proceed as follows:



CAUTION

When changing the batteries, do not disconnect the instrument from the mains supply! The instrument requires a voltage supply to save the data. There is no risk to the user.

1	Switch off the measuring instrument but do not disconnect it from the mains supply
2	Remove any cells from the instrument
3	Remove the lamp module and undo the plug-in connection (see 5.1.1 CHANGING THE LAMP MODULE)
4	Carefully turn the measuring instrument around and safely disconnect it
5	Remove the card with the short instructions
6	Undo the 5 screws on the underside of the instrument using a Phillips screwdriver

- 7 Remove the underside of the housing and lay it to one side

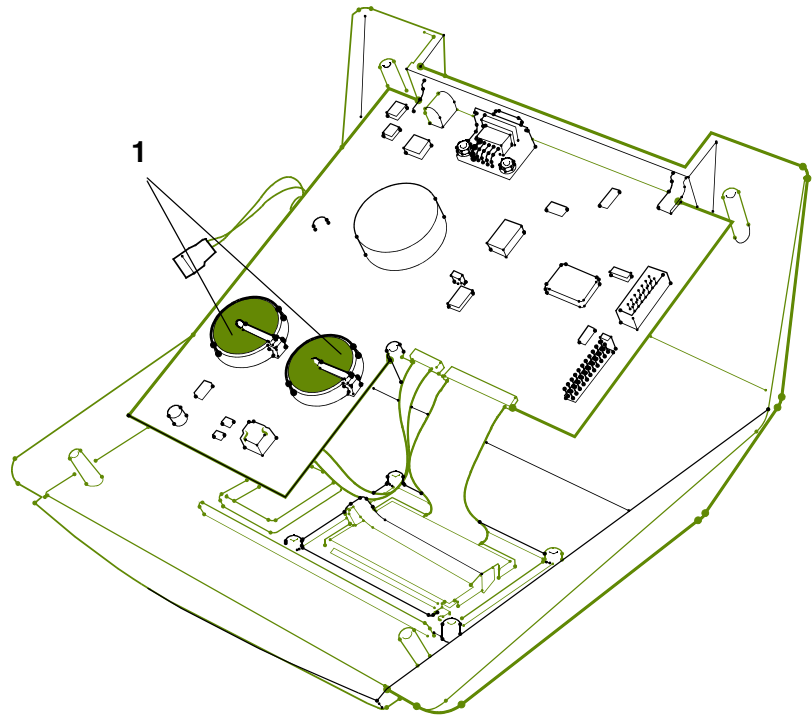

- 8 Remove the two old batteries (1) and dispose of them (see 5.3 DISPOSAL)
- 9 Insert two new batteries (CR3032 lithium batteries) so that the positive poles point towards the clip of the battery holder
- 10 Reattach the underside of the housing and guide the plug-in connector for the lamp module through the opening on the side. Tighten up the five screws again
- 11 Insert the card with the short instructions
- 12 Erect the instrument again
- 13 Attach the lamp module and insert it again (see 5.1.1 CHANGING THE LAMP MODULE)
- 14 Switch on the instrument
- 15 Calibrate the instrument (see 4.4 CALIBRATION). The instrument is now ready for operation again.

5.2 Cleaning

5.2.1 Cleaning the measuring instrument

Occasionally wipe the outside of the measuring instrument with a damp, lint-free cloth. Disinfect the housing with isopropanol as required.



CAUTION

Avoid contact with acetone or similar detergents that contain solvents as these can damage the housing. Remove any splashes immediately.

5.2.2 Cleaning the cells

Cells used for measuring turbidity must always be clean, dry and free of fingerprints. Therefore, clean them regularly:

1	Clean cells inside and out with hydrochloric acid or laboratory soap
2	Rinse out several times with distilled water
3	Let them dry in the air
4	Only hold cells by the top or by the light protective cap so that the optical path is not impaired

5.3 Disposal

Packing

The measuring instrument is sent out in a protective transport packing.

We recommend: Keep the packing material in case you have to send the measuring instrument back for service. The original packing prevents the measuring instrument from being damaged during transport.

Batteries

This note refers to the battery regulation that applies in the Federal Republic of Germany. We would ask end-consumers in other countries to follow their local statutory provisions.



Note

In compliance with §14 of the battery regulation we would like to point out that this instrument contains batteries. Batteries that have been removed must only be disposed of at the recycling facility set up for this purpose or via the retail outlet. It is illegal to dispose of them in household refuse. This also applies to the disposal of the instrument at the end of its operational life.

Calibration standards

The used calibration standards can be disposed of together with the household refuse.

6 What to do if ...

Error message E-01	Cause	Remedy
	– Wrong calibration standard used	– Use the correct calibration standard
	– The lamp is defective	– Replace the lamp module

Error message E-02 or E-03 or E-04	Cause	Remedy
	– Wrong calibration standard used	– Switch the instrument off. Switch the instrument on again and repeat the calibration using the correct calibration standard

Error message E-05	Cause	Remedy
	– The lamp is defective	– Replace the lamp module

“- - -” display	Cause	Remedy
	– The instrument is measuring but the measured value is not yet stable	– Wait for a stable measured value
	– There is a foreign body in the cell shaft	– Remove the foreign body

“LoBat” display flashes	Cause	Remedy
	– The backup batteries are almost empty	– Change the batteries (see 5.1.2 CHANGING THE BATTERIES)

“Cal” display flashes	Cause – The calibration interval set up has expired	Remedy – Calibrate the instrument (see 4.3 CALIBRATION)
Measured values that are obviously too high	Cause – Cell contaminated – Cell scratched – Cell misted up – Air bubbles in the cell – Measuring instrument needs to be calibrated	Remedy – Clean the cell – Replace the cell – Regulate the temperature of the sample before measuring – Remove any air bubbles – Calibrate the measuring instrument
The sample does not run out of the flow-through vessel	Cause – The end of the outlet hose is placed too high – There is a foreign body in the flow-through vessel	Remedy – Place the end of the hose lower than the measuring instrument – Remove the foreign body
The instrument does not react to pressing the keys	Cause – No energy supply	Remedy – Connect the plug-in power supply with the measuring instrument and the mains power supply

**Note**

If a fault cannot be remedied, send the instrument to WTW.

7 Technical data

Ambient temperature	Storage	- 25 °C ... + 65 °C
	Operation	+10 °C ... + 40 °C
Energy supply	Plug-in power supply	Friwo FW7207/15 Friwo Part-No. 1812285 Input: 100 - 240 V~ ± 10% / 47 - 63 Hz / 400 mA (Installation category II) Output: 15 VDC / 1 A
	Backup batteries	2 x 3.0 V lithium battery CR3032
	Battery lifetime	Approx. 3 years
Dimensions and weight of the instrument	Depth	290 mm
	Width	252 mm
	Height	100 mm
	Weight	1 kg
Sample temperature	10 - 40 °C	
Measuring principle	Nephelometric	
Light source	Turb 550	Tungsten lamp
	Turb 550 IR	IR LED
Measuring range	NTU (= FTU = FNU)	0 - 1000

Resolution	For the range, 0.01 - 9.99 NTU	0.01 NTU
	For the range, 10.0 - 99.9 NTU	0.1 NTU
	For the range, 100 - 1000 NTU	1 NTU
Accuracy (± 1 digit)	± 2% of the measured value or ± 0.01 NTU	
Reproducibility	< 1% of the measured value or ± 0.01 NTU	
Response time	Under 3 seconds	
Calibration	Automatic 1 - 3-point calibration	
Printer output	Unidirectional RS232 output	
Test marks	CE, cETLus	
Other data	<ul style="list-style-type: none">● Automatic self-check● Integrated real-time clock● Battery-powered clock and settings for 3 years without any external energy supply● GLP function (calibration interval monitoring)	

8 Accessories (options)

Description	Model	Order no.
Calibration standards 0.02 - 10.0 - 1000 NTU	Kal. Kit P Turb 550/550 IR	600542
Pour-through vessel for turbidity measuring instruments	D-Turb	600600
Flow-through vessel	Flow-Turb	600605
Empty cells for turbidity measuring instrument, 3 pieces	Cell Turb/SET	600601
Cell holder for 6 cells	KS-Turb	600602
Spare lamp module for Turb 550	Lamp Turb 550 WL	600603
Spare lamp module for Turb 550 IR	Lamp Turb 550- IR	600604
Cable to connect to a printer	AK/LQ300	250046
Cable to connect to a PC	AK Labor	902758
Printer	LQ 300	250746

9 Abbreviations and index

This chapter contains additional information and orientation aids.

Abbreviations

The list of abbreviations describes displays and abbreviations that may be encountered when using the measuring instrument.

Index

The index helps you find specific information.

List of abbreviations

ARng	AutoRange: Automatic range switching; Measuring instrument measures at the highest possible resolution
Auto	Automatic measuring mode
Cal	Calibration
E1 - E5	Error message (see WHAT TO DO IF ...)
NTU	Nephelometric turbidity units
FTU	Formazin turbidity units
FNU	Nephelometric formazin units
LoBat	Low Battery: Batteries almost empty

Index**A**

adapter14
air bubbles19
aligning a marked cell18
aligning an unmarked cell18
Aligning and marking a cell17
authorized use10

B

balancing cells18
basic settings34
baud rate31

C

calibration interval31
calibration standards27
cell outside mists up26
condensate forming10, 26
configuring31

D

date setting31
delivery status34
DIN/ISO measurements27
display7

E

error messages43

F

flow-through vessel23
formazin calibrations27

I

initial commissioning13
initialize34

K

keypad6

M

mark a cell 17
measuring accuracy adjustment 27
measuring accuracy check 27
measuring range selection 21

O

operational safety 10
options 47

P

print function 22, 31, 35
printing 35

R

reset 34
resolution selection 21
RS232 interface 35

S

safety 9
safety precautions 9
sample printout 22, 30
scope of delivery 13
short instruction 13
sockets 7
standard measurement 20
standard methods 27
storing a measured value 21

T

target group 9
time setting 31

W

warm-up time 20, 23

